

769 LW TUBE SOCKET WELD ELBOW

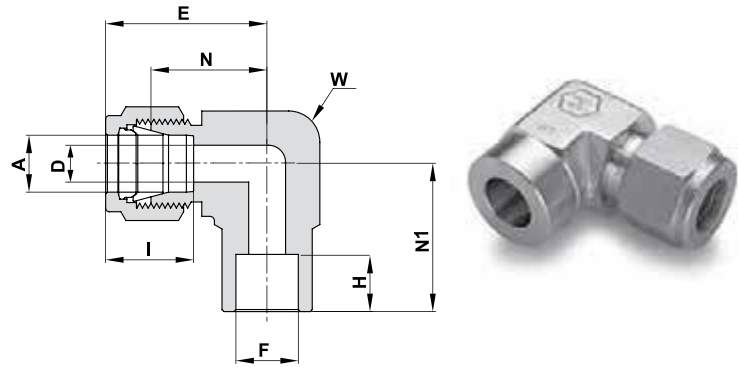

TUBE (INCH)

Ordering Information	A Tube O.D.		F Tube O.D.		D		W Wrench Flat		N		H		E		N1		I	
	inch	mm	inch	mm	inch	mm	inch	mm	inch	mm	inch	mm	inch	mm	inch	mm	inch	mm
769LW _ 1/4 X 1/4	1/4	6.35	1/4	6.35	.19	4.82	1/2	12.7	.77	19.60	.31	7.87	1.06	26.98	.77	19.60	.60	15.2
769LW _ 3/8 X 3/8	3/8	9.52	3/8	9.52	.28	7.11	5/8	15.9	.91	23.11	.38	9.65	1.20	30.98	.91	23.11	.66	16.8
769LW _ 1/2 X 1/2	1/2	12.70	1/2	12.70	.41	10.41	15/16	23.8	1.02	25.90	.50	12.70	1.42	36.06	1.02	25.90	.90	22.9
769LW _ 3/4 X 3/4	3/4	19.05	3/4	19.05	.62	15.74	1 1/16	27.0	1.17	29.71	.56	14.22	1.57	39.87	1.17	29.71	.96	24.4
769LW _ 1 X 1	1	25.40	1	25.40	.88	22.35	1 3/8	34.9	1.45	36.83	.75	19.05	1.93	49.02	1.45	36.83	1.23	31.2

Designation:

Marking LW on Flat

769 LT REDUCING ELBOW

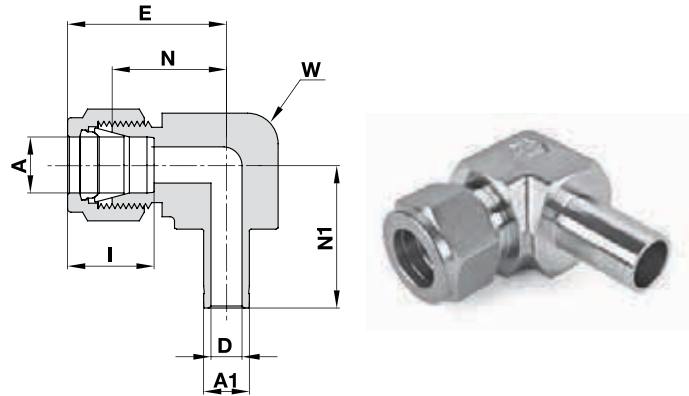

TUBE (METRIC) TO STUB (METRIC)

Ordering Information	A Tube O.D.		A1 Tube O.D.		D		W Wrench Flat		N		E		N1		I	
	mm	mm	mm	mm	mm	mm	inch	mm	mm	mm	mm	mm	mm	mm	mm	
769LT _ 6 X 6	6	6	6	6	4.0	4.0	1/2	12.7	19.6	19.6	27.0	23.8	23.8	15.3	15.3	
769LT _ 12 X 12	12	12	12	12	8.8	8.8	1 1/8	28.6	27.9	27.9	38.0	40.4	40.4	22.8	22.8	
769LT _ 15 X 15	15	15	15	15	12.0	12.0	1 1/8	28.6	27.9	27.9	38.0	41.0	41.0	24.4	24.4	
769LT _ 22 X 22	22	22	22	22	18.3	18.3	1 3/8	34.9	34.5	34.5	44.6	50.0	50.0	26.0	26.0	

TUBE (INCH) TO STUB (INCH)

Ordering Information	A Tube O.D.		A1 Tube O.D.		D		W Wrench Flat		N		E		N1		I	
	inch	mm	inch	mm	inch	mm	inch	mm	inch	mm	inch	mm	inch	mm	inch	mm
769LT _ 1/4 X 3/8	1/4	6.35	3/8	9.52	.19	4.82	5/8	15.9	.91	23.1	1.20	30.5	1.24	31.5	.60	15.2
769LT _ 1/4 X 1/2	1/4	6.35	1/2	12.7	.19	4.82	5/8	15.9	.91	23.1	1.20	30.5	1.28	32.5	.60	15.2

"D" - Dimension is minimum opening. Dimensions are for reference only, and are subject to change without notice.